

# COBRA

## INVERTER GENERATOR USER MANUAL

**Model: IG20SI**

4-Stroke Engine

## Thank you for purchasing a Cobra Inverter Generator

- Cobra reserves the right of modification of product and revision of the manual without any notice.
- Take this manual as a part of the generator. If the generator is resold, it is required to take the manual along with the generator.
- This manual contains how to correctly operate the generator, please read carefully before using the generator. Correct and safe operation will guarantee your safety and extend the working life of generator.
- Cobra will continuously innovate and develop its products both in design and quality. The content of this manual may have minor difference from the updated product. Please contact your supplier for further support.

### **IMPORTANT SAFETY NOTICE:**

**The emission of engines contains poisonous carbon monoxide. Use the generator only outdoors and away from people.**

**NEVER use petrol powered equipment in a home, garage, tent, camper-van, caravan, motor-home or boat. Even if doors, windows or vents are open. Only use outdoors, well away from doors, widows and openings. Prevent inhaling exhaust fumes.**

# CONTENT

01. Safety information .....	04	08. Maintenance .....	22
02. Safety label locations .....	06	1) Change oil .....	22
03. Components identification .....	07	2) Air cleaner service .....	23
1) Control Panel .....	08	3) Spark plug service .....	25
2) ECON.SW .....	08	4) Spark arrester maintenance .....	26
3) Hourmeter .....	09	09. Transporting/Storing .....	28
04. Pre-operation check .....	10	10. Troubleshooting .....	30
1) Check oil level .....	10	11. Technical specifications .....	31
2) Check fuel level .....	11	12. Wiring diagrams .....	32
3) Check air cleaner .....	12	13. Appendix .....	33
05. Starting the engine .....	13	1) Environment correction .....	33
06. Generator use .....	15	2) Noise and access .....	34
1) DC application .....	17	14. Consumer information .....	36
2) AC application .....	18		
3) Output and overload indicator .....	19		
4) Oil alert system .....	20		
07. Stopping the engine .....	20		









# 1. SAFETY INFORMATION

To ensure personal and property safety, please carefully read the following information.

## WARNING

- Read and understand the user manual before using the generator.
- The emission of engine contains poisonous carbon monoxide. Use the generator in the ventilated condition.
- Do not touch the hot muffler, when the generator is running, or before cooling.
- Petrol is explosive and flammable in the specified conditions when refueling, the generator needs to be stopped and be kept cigarette and fire source away.
- Do not connect to the building's electrical system or other generator, in order to avoid the electric shocks and fires.
- The running generator must keep one meter distance with constructions and other electrical appliances at least.
- Place the generator on the leveled surface, in order to avoid overturning or spilling fuel.
- Children and pets should be keep away the operation area.
- Do not operate with wet hand.
- Do not expose the generator to rain, moisture or snow.
- Place the generator at least 1 m away from buildings or other equipments during operation.
- The major repair work should be carried out only by professionally trained person.
- Do not use the generator in underground working
- Do not use the generator in potentially explosive atmospheres
- Use personal protective equipment: glove, mask, earplugs, when you operate or maintain the generator

## SAFETY LABEL:

 <b>WARNING</b>		 <b>WARNING</b>	
	<ul style="list-style-type: none"> <li>• Do not refuel when operating.</li> <li>• Do not refuel while smoking or flames.</li> <li>• Please clean the overflowing fuel.</li> </ul>		<p>Do not connect to a building's electrical system.</p>
	<ul style="list-style-type: none"> <li>• Let the generator cool before storing.</li> <li>• Gasoline is explosive and flammable, please use the generator outdoor.</li> </ul>		<p>Do not expose the generator to rain , moisture or snow.</p>
	<p><b>Never use inside a home or the unventilated condition ( exhaust contains carbon monoxide ).</b></p>		<p>Read the operator's instruction manual before operating.</p>



### 3. COMPONENTS IDENTIFICATION

---

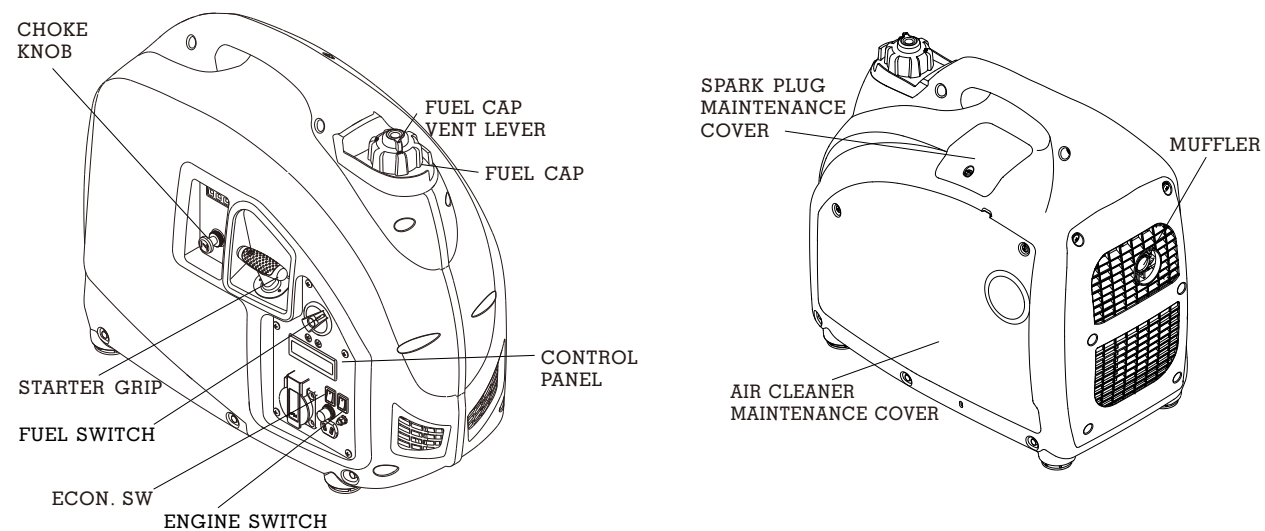

### 3.1) Control Panel

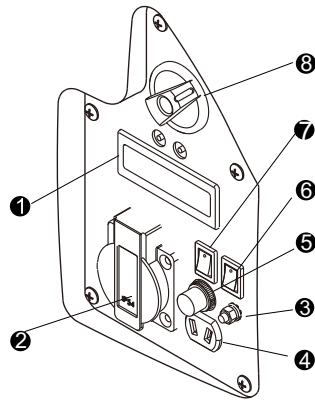

- ❶ Hourmeter
- ❷ AC Receptacle
- ❸ Ground Terminal
- ❹ DC Receptacle
- ❺ DC Circuit Protector
- ❻ Engine Switch
- ❼ ECON. SW
- ❽ Fuel Switch

### 3.2) ECON. SW (Economy control switch):

"ON" (👉👈)

- When the economy control switch is turned to "ON" (👉👈), the engine keeps running at idle state automatically when the electrical appliance is disconnected, and it will return to the proper speed with the requirement of electrical load.
- The "ON" (👉👈) is recommended to minimize the fuel

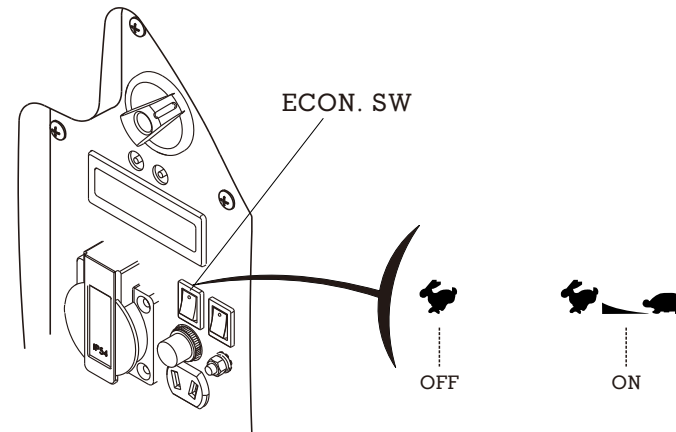



**NOTE**

- When a high load electrical appliance is connected instantaneously, in order to reduce voltage change, turn the economy control switch to the "OFF" (🔌) position.
- In DC operation, turn the economy control switch to the "OFF" (🔌) position.
- Connect both AC load and DC load, turn the economy control switch to the "OFF" (🔌) position.

**"OFF" (🔌)**

When the economy control switch turns to the "OFF" (🔌) position engine runs at high speed.

**3.3) Hourmeter**

- Under the condition of protection, the overload indicator light (red) is on, the "RESET" button can recover the output of the generator, and unnecessary to restart engine overall.
- Press and hold the "RESET" button for one second, until the overload indicator light (red)

will be off, and output indicator light (green) will be on.

- Under the non-overloading condition, the "RESET" is supposed to be ineffective.
- Press DISP; then lighten the backlight.
- Display voltage/frequency, engine speed, cumulative working time in turn.

**NOTE**

- No button in 10S, the backlight shut off.

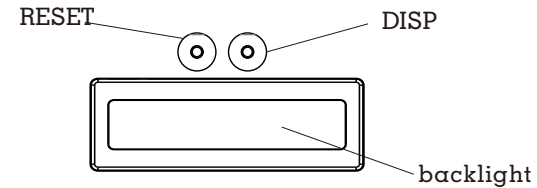

**NOTE**

- For protection condition, the output indicator light (green) is off, and the overload indicator light (red) is on.
- Every starting the engine the "RESET" button is available within 5 times. Otherwise, you need restart the engine.

## 4. PRE- OPERATION CHECK



Be sure the generator is on the leveled surface and the generator is stopped.

### 4.1) Check Oil Level

Remove the oil filler cap, fill the specified amount of the recommended oil and then tighten the oil filler cap .

#### NOTE

- Do not tilt the generator when adding engine oil. This could result in overfilling and damage to the engine.

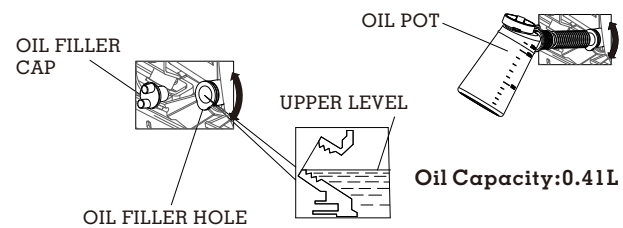

#### NOTE

- Using non-detergent or 2-stroke oil could shorten the engine's working life.
- Using the high quality engine oil with strong detergents
- Using 4-stroke engine oil, certified to meet or exceed API standards: SG, SF ,SAE stickiness rating:

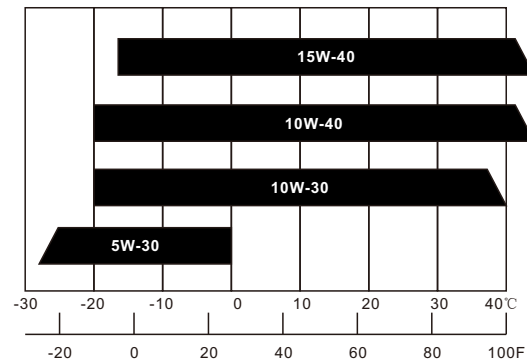

#### NOTE

Carefully use and store the engine oil, avoid getting dirt or dust into the engine oil.

Mixing different kinds of engine oil is prohibited.

#### NOTE

- Before the engine oil reduces below the safety margin, low oil alert system will close the engine automatically. The oil alert indicator light red will be on.
- To avoid the inconvenience caused by unexpected stopping, it is still advisable to check the engine oil level regularly.

#### 4.2) Check Fuel Level

Fuel recommend: use unleaded Petrol  
(Research Octane Number of 91 or higher, Pump  
Octane Number of 86 or higher)  
Never use stale or contaminated Petrol or an oil/  
Petrol mixture,  
Avoid getting dirt or water into the fuel tank.  
Do not use a mixture Petrol containing ethanol or  
methanol; otherwise, it will seriously damage the  
engine.

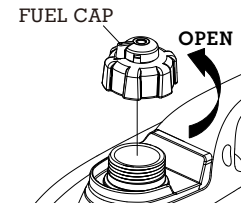

**WARNING**

UPPER LIMIT MARK

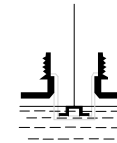

Fuel Capacity: 3.6L

- Petrol is extremely explosive and flammable.
- Around the refueling area and fuel storage area, prohibit smoking and firing.
- Do not overfill the fuel tank (no fuel above the red upper limit mark). After refueling, make sure the fuel cap is closed properly and securely.
- Do not make fuel spill from fuel tank. (No residual fuel around the neck of tank, before starting engine)
- Avoid contacting with skin or breathing the fuel vapor.
- KEEP OUT OF REACH OF CHILDREN.

### 4.3)Check Air Cleaner

Check the air cleaner element to be sure it is clean and in good condition.

a. Loosen three screws of the air cleaner maintenance cover, and remove the cover.

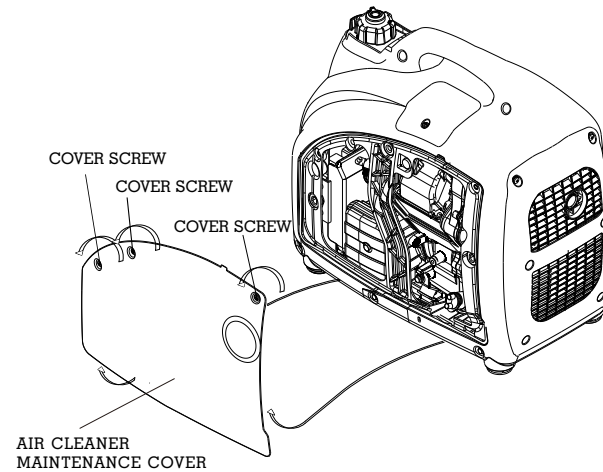

b. Loosen the air cleaner cover screw, and remove the cover

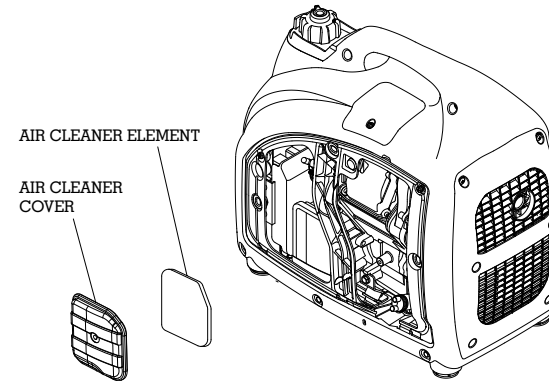

c. Check the element, clean or replace it, if necessary.

#### NOTE

Do not run engine without the air cleaner element. Operating the generator without the filter will damage the engine.

## 5. STARTING THE ENGINE

### NOTE

Before starting engine, disconnect load with AC receptacle.

- 5.1) Turn the fuel cap vent lever to the "ON" position.

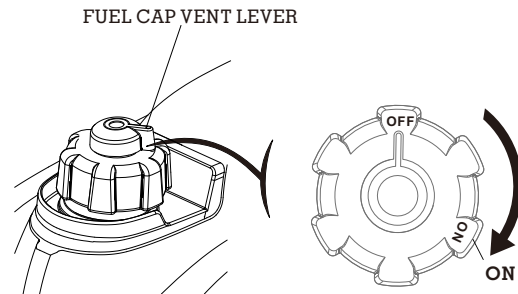

### NOTE

When transporting generator, turn the fuel cap vent lever to the "OFF" position.

- 5.2) Turn fuel switch to the "ON" position.

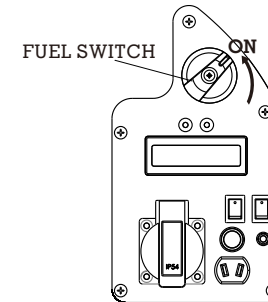

- 5.3) Turn the engine switch to "ON" position.

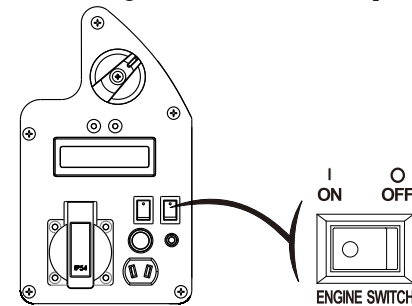

5.4) Pull the choke knob fully out.

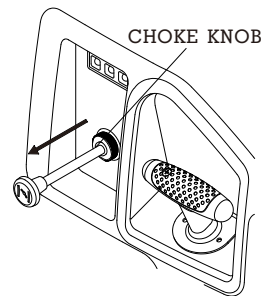

**NOTE**

Do not pull out the choke knob, when engine is hot or ambient temperature is high.

5.5) Pull the starter grip slowly until it is engaged, then pull it quickly.

STARTER GRIP

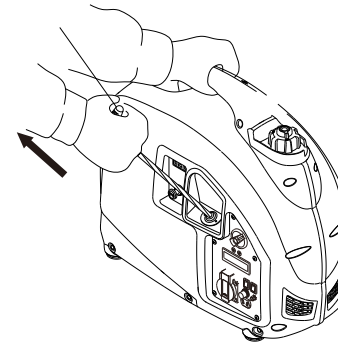

**NOTE**

Return the starter grip slowly by hand. Do not make the starter grip spring back quickly.

5.6) Push the choke knob to the original position, when the engine warms up.

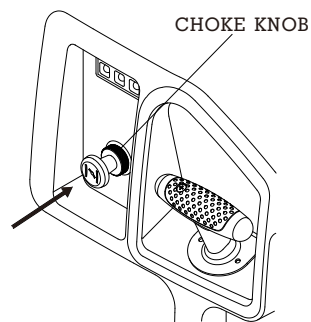

**NOTE**

If the generator stops and can not restart, check the oil level firstly.

**Carburetor Modification for High Altitude Operation**

At high altitude, the standard carburetor air-fuel mixture will be too rich. Performance will decrease, and fuel consumption will increase. A very rich mixture will also foul the spark plug and cause hard starting.

If the generator operates at high altitude, change the main nozzle or adjust the idling screw of carburetor  
If the generator always operates at altitude above

1000 meters contact an authorized Cobra service dealer to modify the carburetor. Generator output power should be modified according to the altitude and ambient temperature. The correction factor refers to 13.2

**▲ WARNING**

If the carburetor has been modified for high altitude operation, the air-fuel mixture will be too lean for low altitude use. Operation at low altitude may cause the engine to overheat and result in serious engine damage. The carburetor needs return to original specifications.

## 6. GENERATOR USE

### **⚠ WARNING**

- Be sure to ground the generator when the connected electrical appliance is grounded.
- Do not connect to the building's electrical system, in order to avoid the electric shocks and fires.

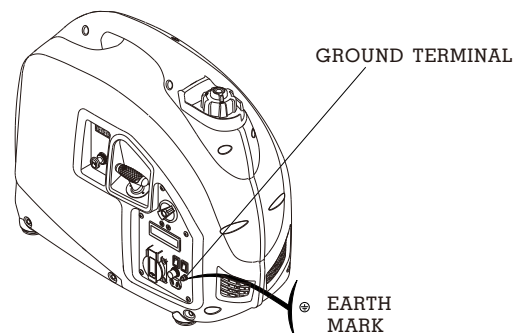

### **⚠ WARNING**

- For continuous operation, do not exceed the rated out-put power of generator.
- Do not make parallel connection with other generators.
- Do not connect an extension to the exhaust pipe.
- When an extension cable is required, be sure to use a tough rubber sheathed flexible cable (according to IEC245 or equivalent standards). The maxmin length of the extension cable: 60m for cable of 1.5mm ; 100m for cable of 2.5mm .
- Keep away from other electric cables or wires.

### **NOTE**

- The DC receptacle can be used while the AC power is in use. If use both at same time, be sure not to exceed the total power for AC and (AC:1.6kVA, DC:5A)
- Most of motor appliances require more than their rated wattage, when starting.



## 6.1) DC Application

The DC receptacle, 15-30V under no load condition, may be used for charging 12V battery only.

### NOTE

In DC operation, turn the ECON SW to the "OFF" (🔌) position.

6.1.1) Disconnect the vehicle battery ground cable from the negative battery terminals.

6.1.2) Connect the DC receptacle to battery terminals with the charging cable

### CAUTION

Connect red lead to positive battery terminal and black lead to negative battery terminal.

6.1.3) Turn ECON SW to "OFF" (🔌) position and then start engine

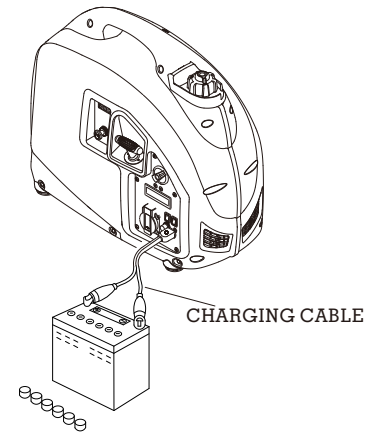

### NOTE

Do not start the automobile engine when the generator is still connected to the battery, otherwise the generator will be damaged.

### Disconnecting the charging cable

- 1) Stop the engine.
- 2) Disconnect the black lead from the negative battery terminal.
- 3) Disconnect the red lead from the positive battery terminal.

4)Reconnect the vehicle battery ground cable.

**⚠ WARNING**

- The battery can release the explosive gases
- Keep the battery away from spark/fire. Charge the battery in ventilated condition.
- Battery electrolyte contains sulfuric acid that will cause severe burn of skin and eyes. Therefore it is necessary to wear the protective clothing and mask.
- If battery electrolyte gets into eyes flush thoroughly with warm water for 15min at least and call a doctor immediately
- If you swallow a little of battery electrolyte accidentally flush thoroughly with water your mouth and then drink large quantities of water or milk with magnesia or vegetable oil and call a doctor immediately

**NOTE**

- The DC receptacle can be used while the AC power is in use .
- When DC circuit overload will trip the DC

circuit protector, remove load firstly, and then reset the protector after a few minutes.

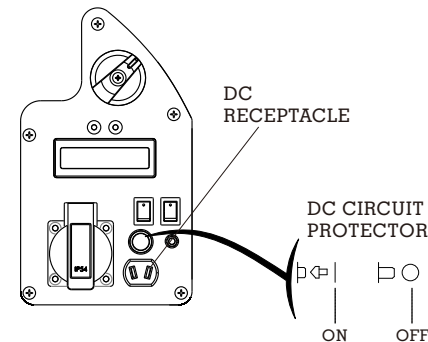

## 6.2) AC applications

6.2.1) Start engine and make sure the output indicator light (green) is on.

6.2.2) Confirm all electrical appliances are switched off, and connect the appliance plugs to the generator receptacle.

**NOTE**

To obtain the best working and longest working life of the generator, a new generator is supposed to run for 20 hours at 50% rated load.

OUTPUT INDICATOR LIGHT (GREEN)

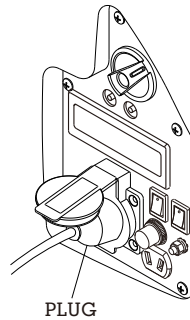
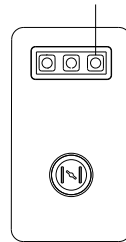

**NOTE**

Confirm all electrical appliances are in good working condition before connecting them to the generator. If an electrical appliance becomes abnormal, sluggish, or stops suddenly, shut off the generator engine immediately, and disconnect the appliance.

**6.3) Output and Overload Indicator**

In normal operating, output indicator light (green) will remain on.

If the generator is overload (over 1.6 kVA), or the connected appliance is short-circuit, the output indicator light (green) is off, and overload

indicator light (red) is on. The AC power will be switched off, but engine is still running.

If the overload indicator light (red) is on, disconnect the electrical appliances firstly, press and hold the reset button 1s. If the overload indicator light (red) is OFF and the output indicator light (green) is on, reconnect the electrical appliances. Otherwise stop the engine and check the generator.

OVERLOAD INDICATOR LIGHT (RED)

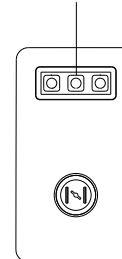

OUTPUT INDICATOR LIGHT (GREEN)

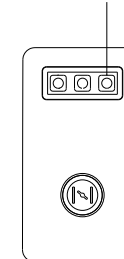

## 6.4) Oil alert system

The oil alert system is designed to prevent engine damage caused by an insufficient amount of oil in the crankcase. Before the oil level in the crankcase falls below a safe limit, the oil alert system will automatically shut down the engine (the engine switch remains in the "ON" position).

If the oil alert system shuts down the engine, the oil alert indicator light (red) will be on. Check the engine oil level.

OIL ALERT INDICATOR LIGHT (RED)

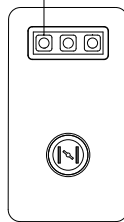

## 7. STOPPING THE ENGINE

To stop the engine in an emergency, turn the engine switch to the "OFF" position.

7.1) Switch off the connected electrical appliances, and pull out their plugs.

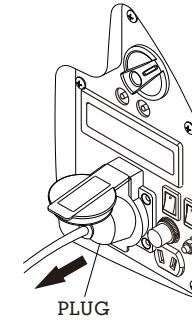

7.2) Turn the engine switch to the "OFF" position.

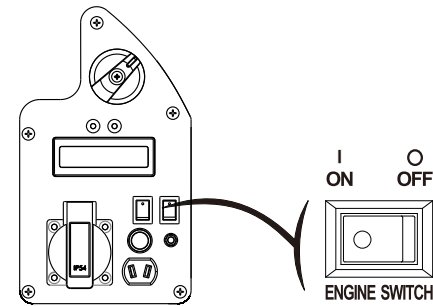

7.3) Turn the fuel switch to the "OFF" position.

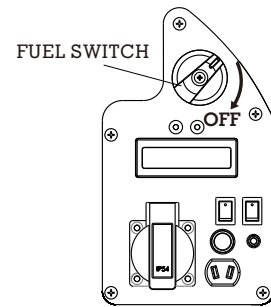

**NOTE**

Be sure the fuel cap vent lever and engine switch locate the "OFF" position, when stopping, transporting and storing the generator.

7.4) Turn the fuel cap vent lever to the "OFF" position.

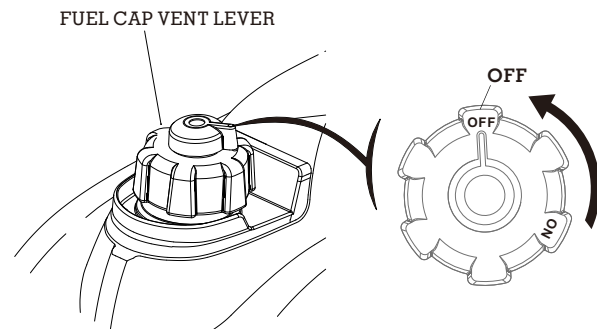

## 8.MAINTENANCE

The purpose of the maintenance and adjustment schedule is to keep the generator in the best operating condition.



Stop the engine before performing any maintenance. If the engine must run, be sure the area is well ventilated. The exhaust contains poisonous carbon monoxide gas.

Use genuine Cobra or equivalent quality components to replace the wear components.

### Maintenance Schedule

Regular Service Period (3)	Item	Each use	First month or 10 hrs.	Every 3 months or 50 hrs.	Every 6 months or 100 hrs.	Every 2 years or 300 hrs.
Engine oil	Check level	⊙				
	Change		⊙		⊙	
Air cleaner	Check	⊙				
	Clean			⊙+(1)		
Spark plug	Check-adjust				⊙	

Spark plug	Replace					⊙
Spark arrester						⊙
Valve Clearance	Check-adjust					⊙+(2)
Combustion Chamber	Clean	After every 300 hrs(2)				
Fuel tank& filter	Clean	Every year(2)				
Fuel line	Check	Every 2 years ( Replace if necessary)(2)				

### NOTE

- (1) Service more frequently when used in dusty areas.
- (2) These items should be serviced by your servicing dealer, unless you have the proper tools and are mechanically proficient. Refer to Cobra manual for service procedures.
- (3) For commercial use, long hours of operation to determine proper maintenance intervals.

### 8.1) Change Oil

Drain the oil rapidly and completely while the engine is still warm.

- 8.1.1) Loosen three screws of the air cleaner maintenance cover, and remove the cover.
- 8.1.2) Remove the oil filler cap.

- 8.1.3) Drain dirty oil into a container thoroughly.
- 8.1.4) Refill the recommended oil and check the oil level.
- 8.1.5) Reinstall the oil filler cap.
- 8.1.6) Reinstall the maintenance cover and tighten the cover screws.

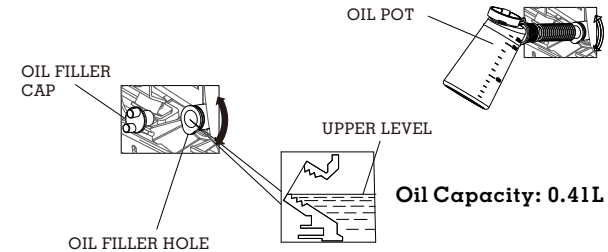
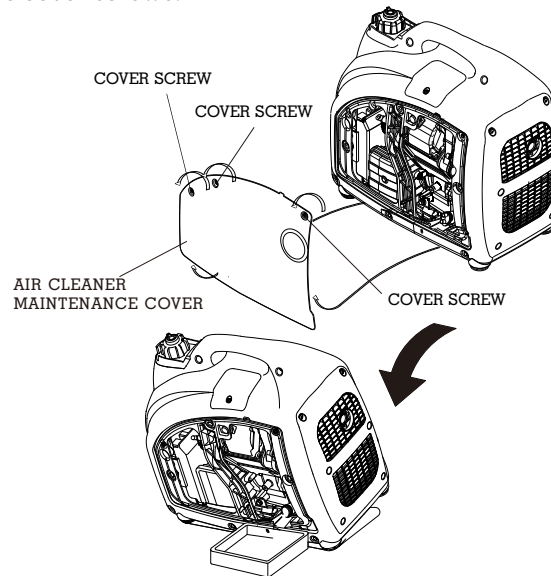

After oil change, wash your hands with soap.

**NOTE**

For conforming to the environment requirement, the used oil will be put into a sealed container and then be transported to the service station for recycler. Do not throw it into the trash or pour it on the ground.

**8.2) Air Cleaner Service**

A dirty air cleaner will restrict air flow into the carburetor. Clean and maintain the air cleaner regularly, especially in the extremely dusty areas.

**⚠ WARNING**

Do not use Petrol or low ignition point solvents for cleaning. They are flammable and explosive under certain conditions.

**NOTE**

Never run the generator without the air cleaner, rapid damage to the engine will occur.

8.2.1) Loosen three screws of the air cleaner maintenance cover, and remove the cover.

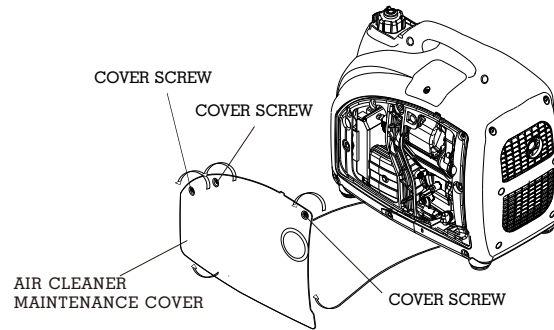

8.2.2) Loosen the air cleaner cover screw and remove the cover.

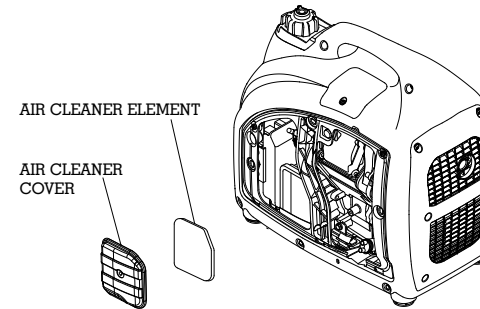

8.2.3) Take out the air cleaner element, and clean it with non-flammable or high flash point solvent, then dry it.

8.2.4) Soak the air cleaner element in the clean engine oil, and squeeze out the redundant oil.

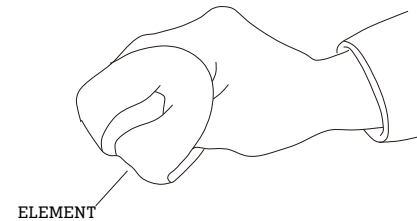



- 8.2.5) Reinstall the air cleaner element and cover.
- 8.2.6) Reinstall the maintenance cover, and tighten the screws.

### 8.3) Spark Plug Service

#### Recommendation spark plug: E6RTC

Check the spark plug gap and clean the carbon deposition at the bottom of the spark plug.

- 8.3.1) Remove the spark plug maintenance cover

SPARK PLUG  
MAINTENANCE COVER

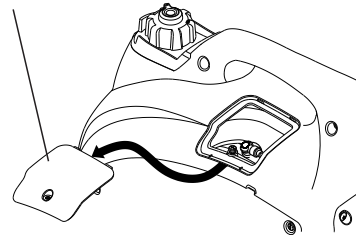

- 8.3.2) Take off the spark plug cap

- 8.3.3) Clean the carbon deposition at the bottom of the spark plug.

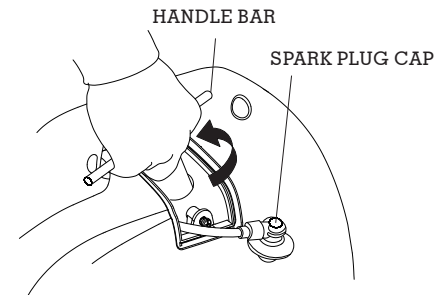

- 8.3.4) Take off the spark plug with the spark plug spanner.

- 8.3.5) Visual inspection the spark plug. Change a new one if its insulator cracked or chipped.

Clean it with a wire brush if the spark plug is reused.

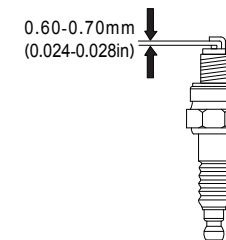

8.3.6) Measure the spark plug gap with a feeler gauge. The normal value:0.6-0.7mm(0.024-0.028in). Adjust the gap by bend one of the electrode carefully.

8.3.7) Reinstall the spark plug carefully, by hand, to avoid cross-threading. A new spark plug should be tightened 1/2 turn with a spanner. A used Spark plug should be tightened 1/8 to 1/4 turn with spanner.

8.3.8) Reinstall the spark plug cap

8.3.9) Reinstall the spark plug maintenance cover.

#### NOTE

- The spark plug must be securely tightened. Tightening in wrong way will cause spark plug hot, even damage the engine.
- Never use a spark plug with an improper heat range.

## 8.4) Spark Arrester Maintenance



The spark arrester must be maintained every 100h service.

8.4.1) Remove the six screws, and remove the muffler guard.

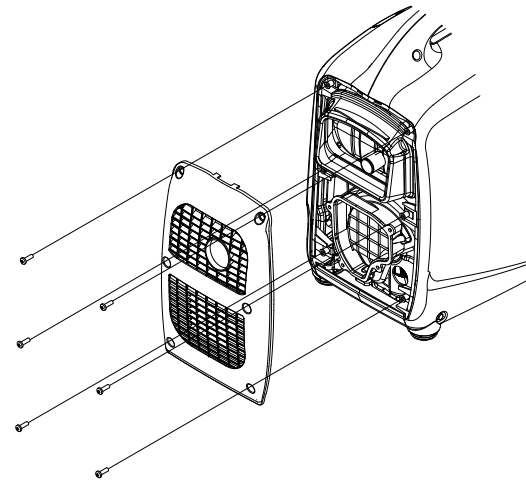

8.4.2) Take off the spark arrester from the muffler after the engine cool down.

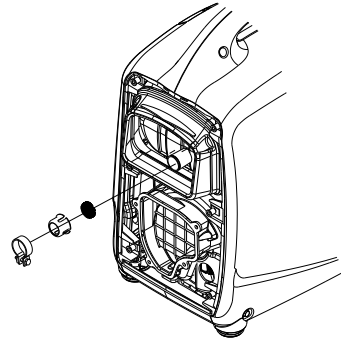

8.4.4) Reinstall the spark arrester and muffler guard.

8.4.3) Use a brush to remove carbon deposits from the spark arrester. If the spark arrester is wear, replace it.

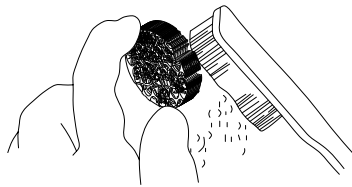

## 9. TRANSPORTING/STORING

Avoid fuel spilling during transporting or temporary storing, both the engine switch and the fuel cap vent lever should turn to "OFF" position, and the generator should place in normal operating position.



### Transporting Generator:

- Do not overfill the fuel tank. (No residual fuel on the neck of tank) It is recommended not to transport the generator with fuel in the tank.
- Do not use the generator on the transport vehicle. The generator should be used under a good ventilated condition.
- Avoid exposing directly in the sunshine when the generator place in the enclosed transport vehicle for a long time. The high temperature inside the vehicle could cause fuel to vaporize resulting in a possible explosion.
- Drain off the fuel, when the generator is transported on rough roads.

Storing for a long period:

- 9.1) Make sure the storage area without excessive humidity and dust.
- 9.2) Drain off the fuel.



Keep away from smoking, flames and spark, Petrol is explosive and flammable in the specified condition.

- α. Drain off the Petrol in the fuel tank, storing into the suitable container.

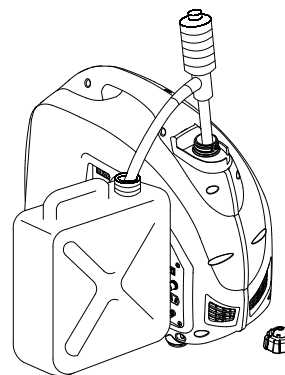

- b. Turn the engine switch to "ON" position, and loosen the carburetor drain screw to discharge Petrol inside of carburetor.

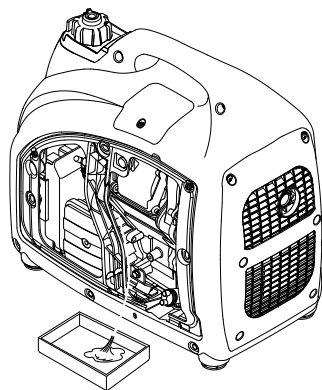

- c. Take off the spark plug cap, pull the starter grip three or four times, discharge the Petrol from the fuel lines.
- d. Turn the engine switch to "OFF" position, and tighten the drain screw of carburetor.
- e. Reinstall the spark plug cap.

STARTER GRIP

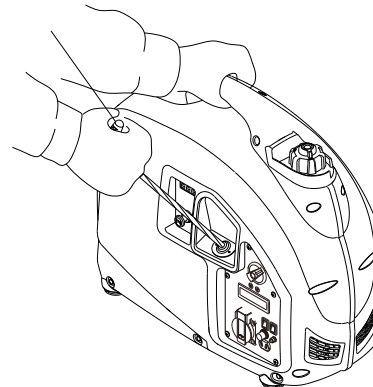

- 9.3) Change the engine oil.
- 9.4) Remove the spark plug, and pour a tablespoon of clean engine oil(10~20ml)into the cylinder. Revolve the engine several times to distribute the oil,and reinstall the spark plug.
- 9.5) Pull the starter grip slowly until feel resistance. At this point, the piston is coming up on its compression stroke and both the intake and exhaust valves are closed. In this position, it helps to protect the engine from internal corrosion.

# 10.TROUBLESHOOTING

When the engine can not be started:

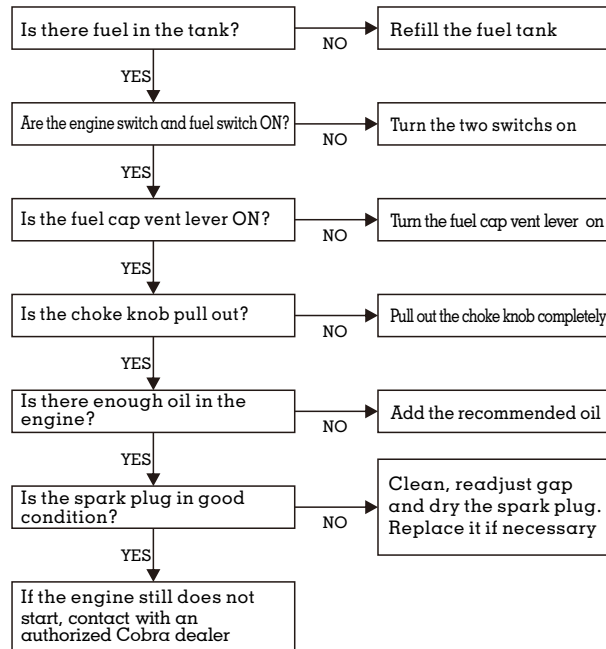

Appliance does not operate :

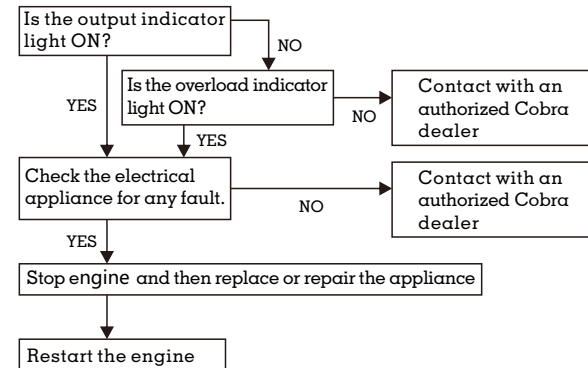

DC receptacle without any electricity :

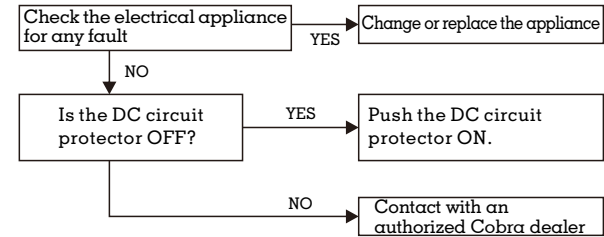

## 11. TECHNICAL SPECIFICATIONS

	Specifications	Parameters	
ENGINE	Model	DJ148F	
	Type	4-stroke, overhead valve, single cylinder, forced-air cooling	
	Engine Displacement	79cm <sup>3</sup>	
	Bore * Stroke	48.6mm*43.0mm	
	Compression Ratio	9:1	
	Rated Speed	2.2/5000min <sup>-1</sup>	
	Ignition System	Full transistor	
	Start System	Recoil starter	
	Fuel Type	Petrol without lead	
	Oil Capacity	0.41L	
	Oil Model	SE 15W-30	
	GENERATOR	Model	IG20SI
		Rated Frequency	50Hz
Rated Voltage		230V	
Rated Current		7.0A	
Rated Speed		4500min <sup>-1</sup>	
Rated Output Power		1.6kVA	
Max. Output Power		2.0kVA	

OTHER SPECIFICATIONS	DC Output	12V/5A
	Fuel Tank Volume	3.6L
	Continuous Running Time	3.9h
	Fuel Consumption	550g/kW.h
	Working Ambient Temperature	-20℃~40℃
	Max. Altitude	1000m
	* Noise L <sub>WA</sub>	90dB/4m
	* * Noise L <sub>PA</sub>	54~59dB/7m
	Dimensions (L*W*H)	507mm*451mm*285mm
	Net Weight	20kg

Noise level is measured when the ECON.SW is turned to " ON " (🔌🔌)

\* : L<sub>WA</sub> shows the guaranteed sound power tested by 2000/14/EC.

\* \* : The noise level in "dB/7m" is the arithmetic mean value of sound press level (L<sub>PA</sub>) in four directions measured 7 meters away from the generator.

The noise level may vary in different environments.

# 12 WIRING DIAGRAMS

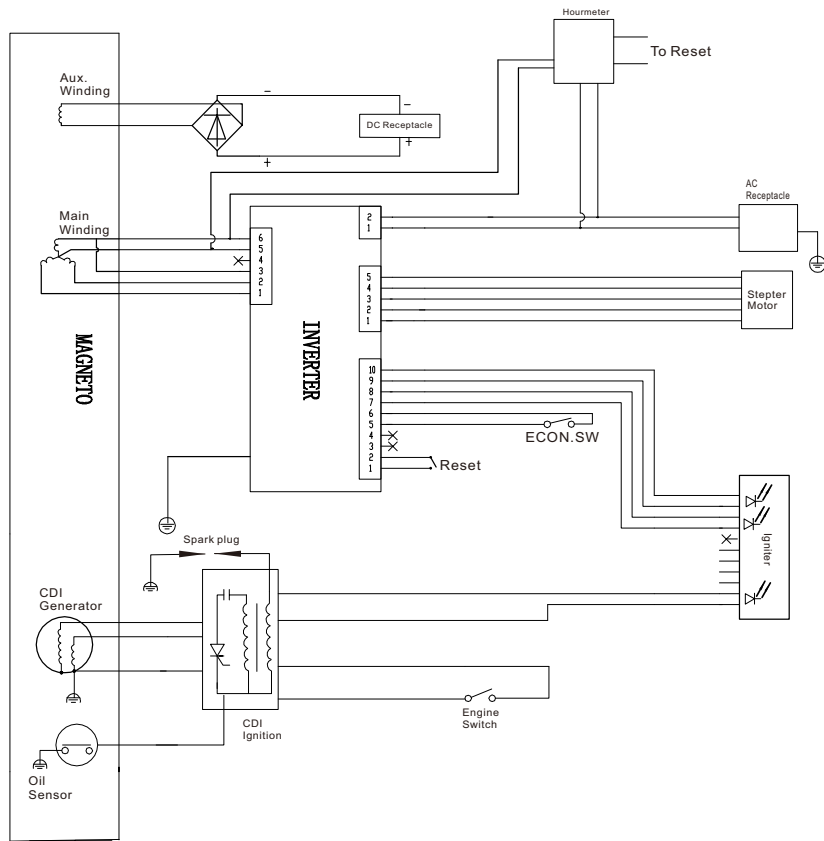



## 13. APPENDIX

### 13.1) Environment Correction

The standard condition of rated power output:

Altitude:0m

Ambient temperature:25°C

Relative humidity:30%

**NOTE:** Relative humidity 60% correction factorC-0.01 ;  
Relative humidity 80% correction factorC -0.02 ;  
Relative humidity 90% correction factorC-0.03 ;  
Relative humidity 100% correctionfactorC-0.04 ;

Factor of environment correction:

Altitude(m)	Ambient temperature°C				
	25	30	35	40	45
0	1	0.98	0.96	0.93	0.90
500	0.93	0.91	0.89	0.87	0.84
1000	0.87	0.85	0.82	0.80	0.78
2000	0.75	0.73	0.71	0.69	0.66
3000	0.64	0.62	0.60	0.58	0.56
4000	0.54	0.52	0.50	0.48	0.46

Example :  
Rated power ( P<sub>N</sub> ) 1.6kVA generator(Altitude:  
1000m) Ambient temperature: 35 , Relative  
humidity: 80%

$$P = P_N * (C - 0.02) = 1.6 * (0.82 - 0.02) = 1.28 \text{ kVA}$$

### 13.2) Noise and Access

Noise emission measure according to ISO 8528-10,  
EN ISO 3744, European Directive 2000/14/EC with  
amendment 2005/88/EC

Model of generator set: IG20SI

Sound Pressure Level: 68 dB(A)

Guaranteed Sound Power Level 90dB(A)

Measurement Uncertainty K: 1.7 dB(A)

The quoted figures are emission levels and are not necessarily safe working levels. Whilst there is a correlation between the emission and exposure levels, this cannot be used reliably to determine whether or not further precautions are required. Factors that influence the actual level of exposure of work-force include the characteristics of the

work room, the other sources of noise, etc, i.e. the number of machines and other adjacent processes, and the length of time for which an operator is exposed to the noise. Also the permissible exposure level can vary from county. This information, however, will enable the user of the machine to make a better evaluation of the hazard and risk.



## EC DECLARATION OF CONFORMITY

We herewith declare,	Cobra Garden Machinery Henton & Chattell Ltd, London Road, Nottingham NG2 3HW United Kingdom
that the following machine complies with the appropriate basic safety and health requirements of the EC Directive based on its design and type, as brought into circulation by us.	
In case of alteration of the machine, not agreed upon by us, this declaration will lose its validity	
Machine Description:	Inverter Generator
Machine Type:	IG20SI (HY20i)
Engine Displacement:	79 cm <sup>3</sup>
Rated Output Power	1.6 kVA Max 2.0 kVA
Measured sound power level	68 dB(A)
Guaranteed sound power level:	90 dB(A) Notified Body for EC Directive 2000/14/EC:0499 TÜV Rheinland LGA Products GmbH Tillystrasse 2, 90431 Nürnberg, Germany 0197
Applicable EC Directives:	2006/42/EC 2006/95/EC 2004/108/EC 2000/14/EC amended 2005/88/EC
Applicable Harmonized Standards:	EN 12601:2010 EN 61000-6-2:2005 EN 61000-6-4:2007
Authorized Signature/Date/Place:	 Peter J. Chaloner 10/1/2019
Title of Signatory:	Managing Director
Name and address of the person authorized to compile the technical file	Cobra Garden Machinery Henton & Chattell Ltd, London Road, Nottingham NG2 3HW United Kingdom

## 14. CONSUMER INFORMATION

### Consumer Service Information

Please contact your retailer for any service related issues in the first instance.

As appropriate you may be referred to another Cobra dealer who is professionally trained to complete service work as necessary. The Cobra dealer list is available at [cobragarden.co.uk](http://cobragarden.co.uk) or contact 0115 986 2161 for assistance.

When contacting your dealer, please have the following information to hand:

- Model and serial number
- Date of purchase
- Detailed description of the problems
- Dealer contact information and your: name, address, and telephone number

**COBRA**

---

Cobra Garden Machinery  
Henton and Chattell Ltd, London Road, Nottingham  
NG2 3HW UK

